

JOINING PLATE ASSEMBLY

GEAR JACK GJ-JP

1 Loosely attach all four Double Track Nuts to the Joining Plate with (8) 10-24 x 5/8" Socket Head Screws and washers.

3 Slide the second pair of Double Track Nuts into the mating slots of the section of Gear Track® to be joined. Position as needed and tighten all fasteners securely.

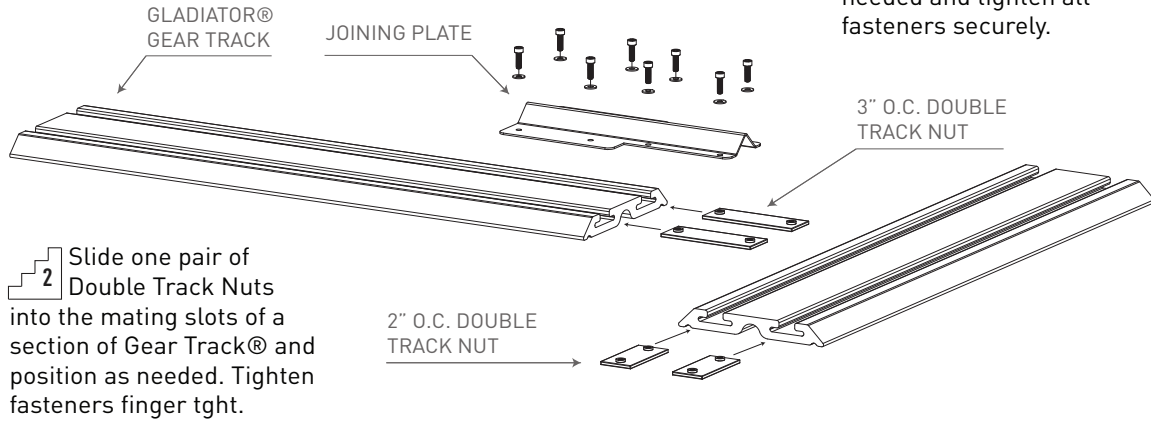

TOOLS Required: 5/32" Hex Key

